

# Bumpers

## EXTRA LENGTH LAMINATED DOCK BUMPER SPECIFICATION

Model B4510-##-AD

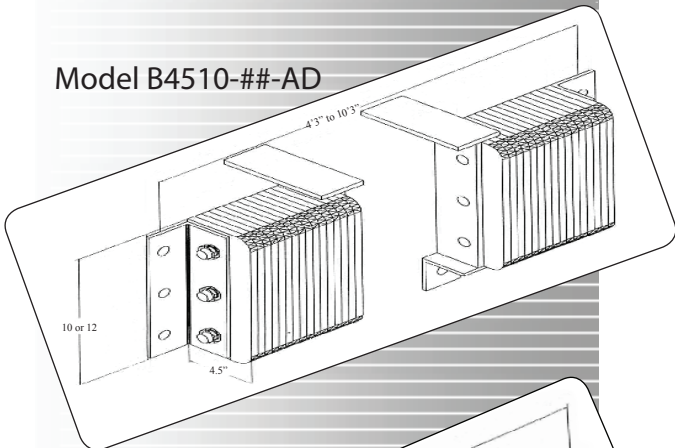

Model B610-##-AD

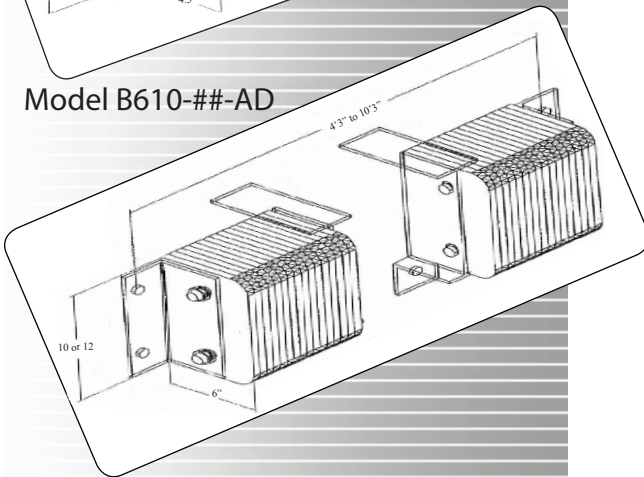

Bumpers offer important protection for your entire dock investment. They provide maximum protection against vehicle damage to the dock, leveler, building walls, restraint and seals/shelters.

### Design Highlights

- Absorbs over 80% of truck impact and shock to protect dock and building
- Eliminates costly repairs from severe shock to docks
- Constructed to last and provide years of protection
- Available in 4.5" or 6" projection; 10" to 12" heights; 4.3" to 10.3" width
- APS Resource warrants this product will be free from defects in material and workmanship under normal use for (1) year

### Anchor Devices for Extra-Length Bumpers

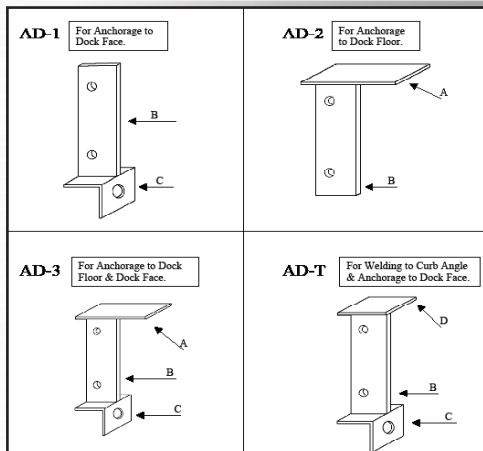

Note: If not otherwise specified- AD-3 Anchorage Device will be provide.

### Project Information

Job Name \_\_\_\_\_

Address \_\_\_\_\_

General Contractor \_\_\_\_\_

Distributor \_\_\_\_\_

Model \_\_\_\_\_

Quantity \_\_\_\_\_

### Certified For Construction

By \_\_\_\_\_

Company \_\_\_\_\_

Address \_\_\_\_\_

Date \_\_\_\_\_