



APS Resource®
Your Aftermarket Solution



APS offers **Products and Solutions**
to help keep your facilities running at peak
performance, improve energy efficiency, and
enhance safety throughout your entire warehouse
and loading dock.



TABLE OF CONTENT

GATES & BARRIERS	1 Dock Impact Barrier
	1 Dock Impact Barrier LC
	1 DUAL CHAIN
PRODUCT UPGRADES	2 Work Safe Gate
	2 Security Gates
	3 LED Light Upgrades
ENERGY SAVING PRODUCTS	3 HTC - Hydraulic Conversion Kit
	3 ATC - Air Conversion Kit
	4 Energy Guard Retrofit Kits
DOCK LIGHTING	4 Dock Leveler Weatherseal
	4 Chain Sealr
	4 Rear Hinge Seal
	5 Door Weatherseal
	5 WeatherWall
	5 Edge Sealr
	5 Dock Stufr
	5 Door Sprag
	6 Ultra-Flex LED Dock Light
	6 High Impact LED
COMMUNICATION LIGHTS	6 E-Saver LED Lamps
	7 Tactical LED Dock Light
	8 APS&GO 2.0
WAREHOUSE DOCK FANS	8 Aerial Safety Lights
	8 Reflect & Guide Stripes
	8 LED Guide Lights
PROTECTIVE SYSTEMS	9 Turbo-ES Fan
	9 Turbo-2040 Kit
SAFETY PRODUCTS	9 Dock Light/Fan Combo
	10 Impact-A-Track LED
	10 Impact-A-Track Reflect
	10 Goal Post
	11 FLEX-BACK Panel
	11 Sentry Rail
	11 Sentry Rail LT
	12 Trak-Sentry
	12 Z-Guard
	12 Poly-Barrel Column Protector
	13 Steel Column Protector
	13 Rack Post Protectors
	13 Drain Pipe Protectors
	14 Fork Sentry
	14 End of Rack Protectors
	14 Wheel Chocks & Chains
15 Wheel Guides	
15 Bumpers	
16 Bollards and Barriers	
16 Trailer Stabilizer	

WHO WE ARE

For over 25 years, APS Resource has been the leading supplier of loading dock equipment replacement parts and warehouse safety equipment for your busy facilities. APS Resource is dedicated to providing you with high quality equipment, reducing your facility's downtime, and helping you preserve the significant financial investment that you have made in your loading dock and warehouse equipment.

APS Resource's comprehensive offerings include energy saving systems, LED dock lights, specialty door panels, gates and barriers, protective systems, and product upgrades. Our products are sold through an extensive network of trained distributors who provide superior installation and service.

YOUR AFTERMARKET SOLUTION

APS Resource was founded to support the material handling distribution network's efforts in providing quality maintenance and repair service to its customers. Since then, we have added our own line of warehouse and loading dock products to upgrade your existing equipment and to enhance the safety and energy efficiency of your facility. Our service levels, timeliness of shipments, order fill rates and shipping accuracy are among the highest in the industry. Whatever your warehouse or loading dock needs, APS Resource has the product and service solutions to fill the order.

SAFETY GATES AND BARRIERS

APS Resource offers dock safety gates and impact barriers to help enhance safety throughout your warehouse. The Dock Impact Barrier series can help provide protection from lift truck traffic. The Work Safe Gate helps to provide a visual barrier for pedestrians and light traffic.

DOCK IMPACT BARRIER™ helps reduce the occurrence of accidents due to fork lift, pallet jack or pedestrians falling off the dock when the door is open.



DOOR SIZE	OVERHEAD CLEARANCE
6'	10' 4"
7'	11' 4"
8'	12' 4"
9'	13' 4"
10'	14' 4"

FEATURES:

- Engineered to help stop a 10,000 lb. gross load at 4 mph
- Top rail meets OSHA standard for withstanding 200 lbs. of force from any direction
- OSHA 1910.29 (fall protection) compliant
- Interlock capable
- Helps protect overhead doors & tracks
- Gas spring assisted for easy, one-handed operation
- High visibility yellow



[\(Scan or click here for product video\)](#)

DOCK IMPACT BARRIER LC™ can help reduce the occurrence of accidents due to fork lift, the pallet jack or pedestrians falling off the dock when the door is open, while still meeting limited overhead clearance requirements.

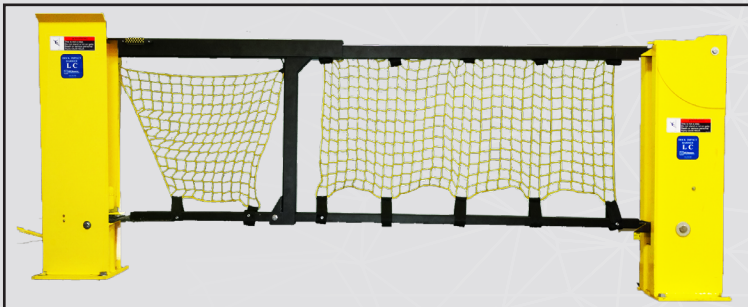

DOOR SIZE	OVERHEAD CLEARANCE
8'	9' 10"
9'	10' 10"
10'	11' 10"

FEATURES:

- Engineered to help stop a 10,000 lb. gross load at 4 mph
- Top rail meets OSHA standard for withstanding 200 lbs. of force from any direction
- OSHA 1910.29 (fall protection) compliant
- Interlock capable
- Helps protect overhead doors & tracks
- Gas spring assisted for easy, one-handed operation
- High visibility yellow

DUAL CHAIN™ is a set of strengthened security chains, engineered and 3rd party tested to adhere to OSHA 1910.29, used to help protect workers from edge of dock accidents.

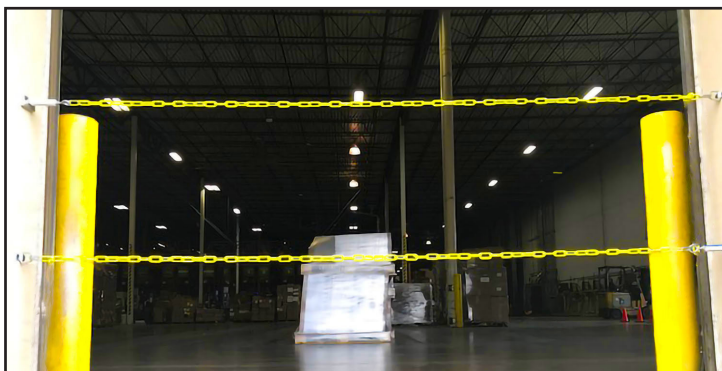

DOOR SIZE
8'
9'
10'

FEATURES:

- Simple manual non-electrical operation
- Unique turnbuckle for ease of adjustment
- Top chain meets OSHA standard for withstanding 200 lbs. of force
- OSHA 1910.29 (fall protection) compliant
- Easy installation
- High visibility yellow chain
- Install on concrete or metal door jambs
- Optional mounting on Sentry Rail post

WORK SAFE GATE™ helps provides excellent visual protection for personnel. The easy to operate gate lifts almost effortlessly out of the opening for complete access.



DOOR SIZE	OVERHEAD CLEARANCE
6'	10' 4"
7'	11' 4"
8'	12' 4"
9'	13' 4"
10'	14' 4"

FEATURES:

- High visibility yellow with striping on the rails of the non-netted version
- Optional netting and Retrofit Kits available for OSHA compliance
- OSHA 1910.29 (fall protection) compliant
- Helps protect overhead doors & tracks
- Gas spring assisted for easy, one-handed operation



[\[Scan or click here for product video\]](#)

SECURITY GATES



Single-slide Security Gate

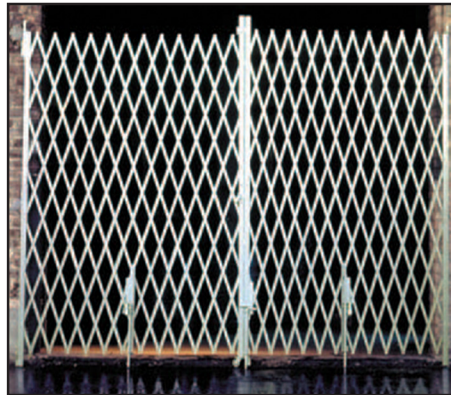

Bi-parting Security Gate

FEATURES:

- Heavy-duty steel construction
- Standard galvanized finish for durability
- These security gates are designed to secure dock doors or ramp doors without sacrificing visibility or air circulation
- Available in single-slide and bi-parting in a variety of widths and heights

ENVIROGATE LT

The EnviroGate LT is the economical way to provide security and safety for your facility at a reasonable price. This gate has similar functionality to our standard security gate while still being environmentally friendly.

FEATURES:

- Made of 100% recycled, recyclable galvanized steel – provides a lower cost option
- This security gate is designed to secure dock doors or ramp doors without sacrificing visibility or air circulation
- 15 gauge galvanized (0.071" thick) steel
- Non-toxic, water based corrosion – restraint finish
- Solid Steel Casters
- Easy to install; do-it-yourself instructions included
- Optional: standoff bracket & self standing post available





PRODUCT UPGRADES

APS Resource has conversion and upgrade kits to get your dock or warehouse operating at peak efficiency. Dock leveler conversion kits and safety upgrades are easy to use but make a big impact on costs and safety.



Inside LED Upgrade



Stoptlight Style LED Upgrade



Composite LED Upgrade

LED LIGHT UPGRADES available for both inside and outside red/green lights. Replace higher maintenance incandescent bulbs with safer, long-lasting LED technology.

FEATURES:

- 90% less energy consumed than a traditional incandescent bulb
- No maintenance, extra long lamp life, high vibration resistance
- Available in 12-24V & 115V low-profile design

HTC - HYDRAULIC CONVERSION KIT™ Fully hydraulic activation in a conversion kit combines ease of operation with low operating costs. Hydraulic main cylinder with hydraulic lip activation makes this kit a complete upgrade for your mechanical or manual leveler. Velocity fuse included for emergency safety. Rated and tested from -65° to +200°F.

FEATURES:

- 1 HP motor/pump assembly
- Hydraulic main cylinder and lip cylinder comes with all necessary hoses, fittings and brackets
- Easy to use, constant pressure push-button control
- Voltage options: single phase 120V or 230V, three phase 230V or 480V

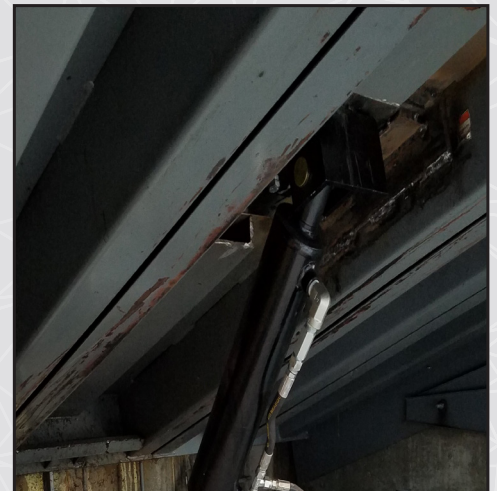

ATC - AIR CONVERSION KIT™ The patented ATC (Air Technology Conversion) Kit will extend the life of your old dock leveler and make it more efficient while lowering your operating costs. The ATC Kit converts mechanical or manual levelers of most major manufacturers and can be installed easily. The durable airbag lifting module operates without loss of performance in temperatures from -65° to +200°F.

FEATURES:

- Low maintenance
- Ergonomic design increases safety and productivity
- Proven technology - tested fully effective at over 200,000 cycles
- Environmentally friendly
- Lowest lifetime ownership cost
- 120V Single Phase





ENERGY SAVING PRODUCTS

ENERGY GUARD RETROFIT KITS™ offers top of the line perimeter seal that helps cover the sides and rear of your dock leveler. The energy-saving solution helps block invasive vermin and insects as well as debris. It can also be used as an extra security measure.

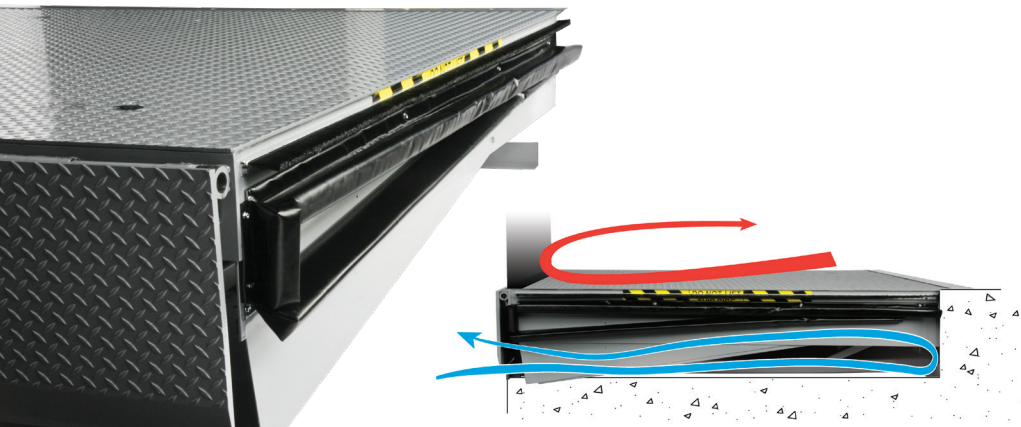

FEATURES:

- Effectively seals off gaps by forming a compression seal around sides and rear of dock leveler
- Side seal assemblies are open cell foam encapsulated with reinforced vinyl
- Effective perimeter seal (sides & back, up to 9" above dock)
- Unrestricted access to pit for cleaning and dock leveler inspection
- Retrofit Kits install easily with common tools

DOCK LEVELER WEATHERSEAL



FEATURES:

- Tek Screw or weld-on style weatherseal available in nylon brush or PVC
- Nylon brush weatherseal deters rodents and insects from entering around the dock leveler
- PVC flexible weatherseal is resistant to heat and cold, and endures years of use

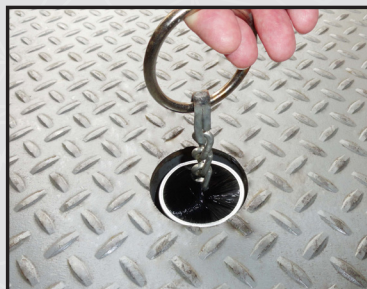

CHAIN SEALR

Deters rodents and insects from entering the facility through the chain opening of the dock leveler



REAR HINGE SEAL

Available in spiral brush seal, foam cord or foam block styles





DOOR WEATHERSEAL



FEATURES:

- Available in common door sizes; 8'2", 9'2", 10'2" and many more sizes
- Available in 1.5", 2" and 3" bristle lengths
- Standard 45°, 90° or 180° aluminum extrusion retainers for effective door sealing
- Preferred choice for Food and Pharmaceutical facilities

WEATHERWALL is a unique style of brush Weatherseal. It has a sheet of EPDM rubber surrounded by a layer of brush on each side.

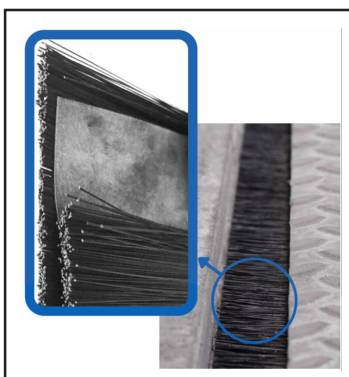
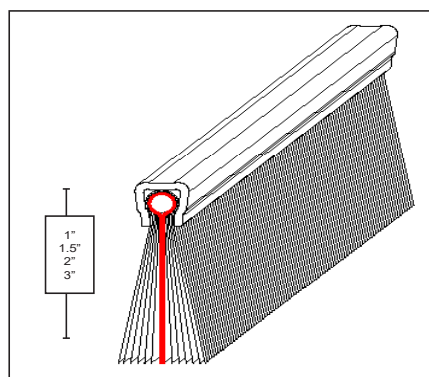

FEATURES:

- Heavy-duty propylene bristles
- Durable, synthetic EPDM airtight membrane
- WeatherWall can be used anywhere you would normally use brush-style weatherseal - doors, docks, conveyors, etc.
- Available in various sizes
- Brush deters rodents and insects from entering around the dock or doors at Food & Pharmaceutical facilities

GAP GUARD The loading dock leveler corner opening is one of the most vulnerable gaps for any warehouse. With the Gap Guard, you can help protect the gap and enhance your loading dock today.



NEW!

FEATURES:

- Helps increase energy savings
- Creates an additional barrier to help keep pests and debris out
- PVC, foam, and brush construction
- Durable design to withstand the loading dock environment
- This product carries a (1) year limited warranty with APS Resource

EDGE SEALR™



FEATURES:

- Effectively seals off the bottom of your dock door
- Constructed of 22 oz vinyl; available up to 22' with or without side flaps

DOCK STUF™



FEATURES:

- Constructed from heavy-duty coated fabric
- Designed to eliminate light gaps between lip and bumper
- Available in two sizes

DOOR SPRAG™

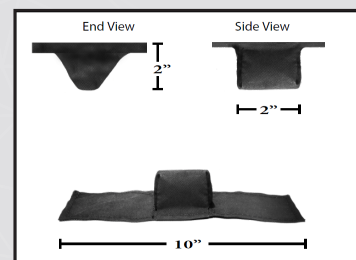

FEATURES:

- Helps fill the gap between the dock leveler or pit wall



DOCK LIGHTING

APS Resource is a recognized leader in providing long-lasting and economical solutions to help safeguard loading dock personnel against accidents. APS Resource offers dock lights in many sizes and variations to meet your needs. LED dock lights can help save a significant amount of energy without sacrificing lighting performance. They can help significantly reduce utility, maintenance and replacement costs.

ULTRA-FLEX LED™ from APS Resource is a high-performing loading dock light. With straightforward features, this dock light will help provide lighting assistance at a busy loading dock. The flexible neck and multiple brightness features compliment a low-profile design that helps prevent the Ultra-Flex LED from disrupting loading dock tasks.

FEATURES:

- Meets requirements for food and pharmaceutical facilities
- Heavy-duty flexible arm
- Impact resistant arm and light housing
- Swivel base for easy positioning
- Two brightness settings
- Convenient On/Off switch
- Low-profile design
- Optional pigtail cable for hardwire or master panel applications

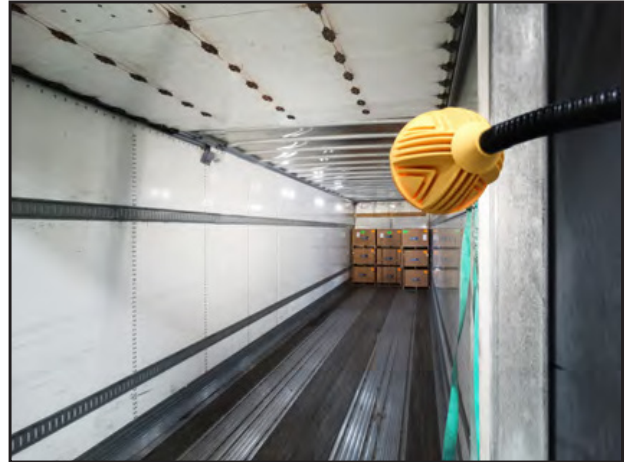

[\(Scan or click here for product video\)](#)

HIGH IMPACT LED™ is designed for your most demanding applications at the loading dock. The rugged, cast aluminum housing with polycarbonate lens is engineered to withstand impact at the loading dock without damage to the light. Bright, energy efficient 18 watt LED with 60,000 hour lamp life saves on utility, maintenance and replacement costs. The High Impact LED Dock Light can be easily retrofitted to existing dock arms or can be mounted remotely.

FEATURES:

- Rugged, compact design for your toughest applications
- Meets requirements for Food and Pharmaceutical facilities
- Impact resistant, durable heavy-duty cast aluminum housing
- Convenient recessed ON/OFF switch
- Rated for Wet locations, IP66, NEMA 4



[\(Scan or click here for product video\)](#)

E-SAVER™ LED LAMPS save a significant amount of energy with a rapid return on investment. Designed with LED optics, the E-Saver LED Lamps gives maximum illumination throughout the truck trailer. The lamp uses 85% less energy than halogen alternatives.

FEATURES:

- Energy Star certified
- Both fit most existing dock lights and light fixtures for easy installation
- Meets requirements for Food and Pharmaceutical facilities
- This product carries a (5) year limited warranty with APS Resource



E-Saver 30™ LED Lamp



E-Saver 38™ LED Lamp

Size	Watts	Lamp Life	Lumens	Beam Spread
Par 30	14W	25,000 hrs.	1150	25°
Par 38	17W		1300	



TACTICAL LED DOCK LIGHT™ is a high performing, next generation of loading dock lights. With enhanced technology and high levels of safety additives, this dock light will outperform your expectations. Dimmable and auto ON/OFF features compliment a more compact design that will not disrupt loading dock tasks.



FEATURES:

- S.W.A.T. built in to light
- Auto ON/OFF feature
- Dimmable
- Heavy-duty flexible arm
- Impact resistant arm and light housing
- Swivel base for easy positioning
- Low profile design
- This product carries a (5) year warranty with APS Resource
- Designed and assembled in USA



[\[Scan or click here for product video\]](#)



APS&GO 2.0 helps ensure safety at the loading dock with communication between warehouse staff and truck drivers. Upgrades available for existing inside and outside red/green lights. Replace higher maintenance incandescent bulbs with safer, long-lasting LED technology.



APS&GO 2.0

FEATURES:

- High visibility red/green LED lights; **X** and **O** symbols help improve communication for visually impaired users
- The APS&GO 2.0 features an even more compact, lower-profile design
- Impact resistant polymer housing resists corrosion
- Long lasting LED technology for added safety and cost savings
- Available to add-on with additional safety & communication lights *(Shown on Vertical Aerial Safety Lights)*

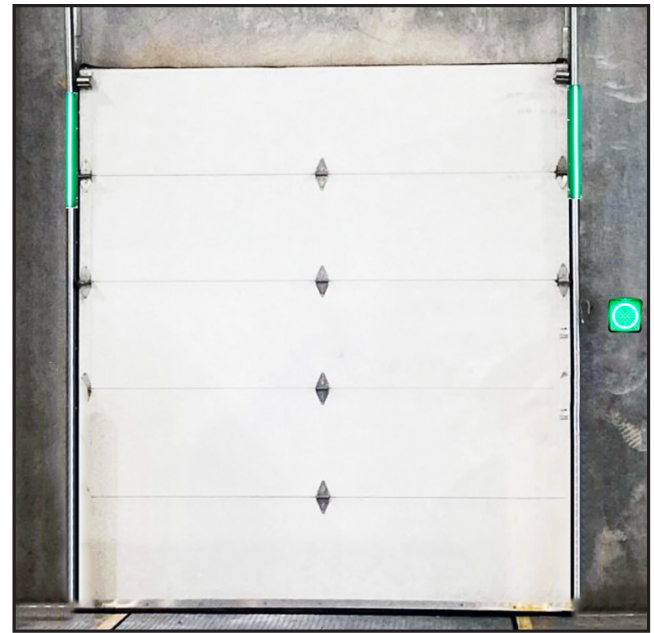

Vertical Aerial Safety Lights

(Shown with APS&GO 2.0 interior light)

FEATURES:

- Vertical aerial mount for high visibility
- Wrap-around design allows for easy door operation
- Impact, rust and moisture resistant
- 120V incoming power
- Easy wire connections
- This product carries a (1) year limited warranty with APS Resource

REFLECT & GUIDE STRIPES™ help enhance safety at the dock and throughout the facility by providing improved visual cues for the truck driver.



FEATURES:

- Weather resistant for long-term performance
- 47,000 microprisms per square inch provide intense reflective property
- No electrical hook-ups, no bulbs to replace and zero energy use
- 4" Wide; 10", 24", 30" long and custom sizes available

LED GUIDE LIGHTS™ provide an ideal focal point for drivers, greatly reducing the risk of "overrunning" the dock. The dual Guide Lights illuminate the dock surface exactly where needed to assist a driver in lining up the trailer square to the dock.

FEATURES:

- 50,000 hr. LED lamp life
- High-impact polycarbonate construction with ribbed reinforcing
- High visibility from compact illumination on both sides of the door opening
- 120V AC or 12/24 VAC/DC operation; dual light system is standard





WAREHOUSE DOCK FANS provides cooling and ventilation where workers need it most. Our fans are mounted & efficient in helping warehouse environments more tolerable.

TURBO-ES FAN The compact Turbo-ES Fan from APS Resource creates a focused column of air that forces hot, cold or musty air from the trailer, replacing it with fresh air. Unlike traditional blade fans that create a broader movement of air, the Turbo-ES fan creates a continuous stream of fresh air that improves the work environment, increasing comfort and productivity. The Turbo-ES Fan's 1275 CFM output provides more airflow at lower amperage than any comparable truck fan on the market!



FEATURES:

- Fully recycles air in a 53' trailer in 121 seconds
- Energy efficient, thermally protected, powerful 1/3 HP, 120V, 3.0 AMP, energy efficient motor
- Easy-grip handle provides convenient adjustment point
- Increases airflow in and out of trailer for improved comfort
- Lightweight, compact size
- Protective grills for safety
- Includes extra long 10' power cord with 3-prong 120V plug
- Dual articulating arm for precise positioning (sold separately)
- Maximum - 1275 CFM output



(Scan or click here for product video)

TURBO-2040 KIT is durable dock product that enhances visibility and air quality on the loading dock. Attached to a hinged dual arm that allows for easy positioning. The product's output qualities makes it an energy conscious solution.

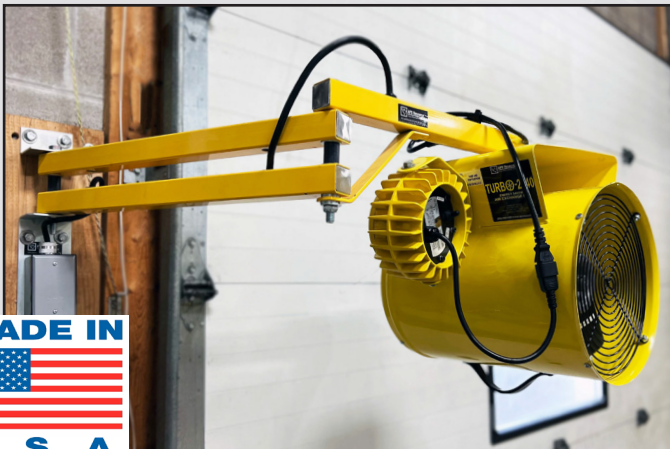

FEATURES:

- No power switches on arm, light or fan; it's to be wired directly to a control panel or separate wall switches
- Dock light lens conforms to FDA & USDA requirements for Food & Pharmaceutical facilities
- Dock fan provides a high-flow, focused column of air
- Optional safety lanyard
- These products carry a (3) year limited warranty
- Maximum - 2040 CFM output
- Built to Amazon specifications



DOCK LIGHT/FAN COMBO helps improve poor lighting and ventilation at the dock.

FEATURES:

- Heavy-duty, 3-speed, 18", for maximum air movement
- Fan CFM is 3,190 (high), 2,970 (medium), 2,660 (low)
- Available with 24", 42", or 62" total arm reach
- Various light heads and optional energy saving lamps available
- UL listed



PROTECTIVE SYSTEMS

APS Resource's protective systems can help eliminate costly repairs to your building. They are designed to protect plant equipment, fixtures and your building.

IMPACT-A-TRACK LED™ is designed to protect door tracks in high traffic areas of warehouse against forklifts, pallet jacks and other equipment. It can be relied on to help communicate restraint or APS&GO 2.0 communication light status. Helps deflect impacts while utilizing only a small footprint of your active work area. This product comes packaged in a set of two.



FEATURES:

- LEDs are protected from damage keeping your restraint status visible
- Wrap-around design allows for easy door operation
- Impact, rust and moisture resistant
- Anchors to wall to avoid drilling into floor
- Compatible with photo eyes
- Three phase communication with vehicle restraint (Red, Green, and Amber)
- Constructed of Ultra High Molecular Weight Polyethylene (UHMWPE)
- Can be installed on 2" and 3" track
- 36" height

IMPACT-A-TRACK REFLECT™ is a cost-effective protection solution for sectional door tracks. Its design helps keep damage in high traffic areas of the warehouse from forklifts, pallet jacks and other equipment to a minimum.



FEATURES:

- High-visibility, reflective yellow safety strips
- Wrap-around design allows for easy door operation
- Compatible with photo eyes
- Impact, rust and moisture resistant
- Anchors to wall to avoid drilling into the floor
- Constructed of Ultra High Molecular Weight Polyethylene (UHMWPE)
- Can be installed on 2" and 3" track
- 36" height

GOAL POST help prevent damage to overhead doorways from forklifts or other equipment.



FEATURES:

- 4" and 6" square tubing are standard
- Offset baseplates provide more service area
- Easy assembly with provided fasteners
- Saves expense of frequent door replacement
- Made in the U.S.A.
- Round Pipe Available

FLEX-BACK PANEL is the answer to common lower door panel damage, one of the most frequent and costly maintenance problems in today's busy warehouse.



FEATURES:

- Flexible panel construction; durable high impact polymer panel skin
- Handles most common door impact at the dock and helps reduce door maintenance cost
- Flexes up to 9 inches in either direction
- Provides excellent thermal seal
- Compatible with tongue and groove or ship/lap door panels
- Installs easily using standard door hardware
- Available in 8'2", 9'2", 10'2", and 12'2" panel sizes
- Custom sizes available



(Scan or click here for product video)

SENTRY RAIL™ helps provide high visibility and structural integrity needed to provide protection throughout your facility.



FEATURES:

- Standard posts available in double rail (42" h) and single rail (18" h)
- Posts are 4" square high strength steel with a 5/8" thick baseplate
- Withstands 10,000 lb. load at 4mph
- Optional Swing Gate, Lift-Out Rail and Offset posts available
- Heavy duty steel construction with powder coated yellow for high visibility and lasting durability
- Engineered to help provide reliable pedestrian and asset protection

SENTRY RAIL LT™ helps provide high visibility and structural integrity needed to provide protection throughout your facility.



FEATURES:

- Heavy-duty steel construction, powder coated safety yellow for high visibility and lasting durability
- 42" double rail meets OSHA standard for fall protection systems
- Lift-Out Rail design provides quick and easy access to protected areas
- 8' rail sections can be cut to custom lengths in the field



TRAK-SENTRY™ wraps securely around the door's tracks without interfering with normal door operation.

FEATURES:

- Heavy-duty steel construction with powder coated safety yellow for high visibility and lasting durability
- Offers maximum protection for your overhead door tracks
- Sold in pairs - 1/8" (LT), 3/16" (SD), 1/4" (HD), and 3/8" (XHD)
- Standard size 48"
- Custom sizes available

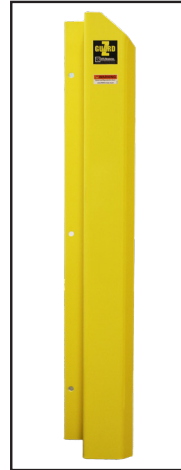

Z-GUARD takes up less valuable floor space by eliminating the base plate.

FEATURES:

- Heavy-duty steel construction with powder coated safety yellow for high visibility and lasting durability
- Offers maximum protection for your overhead door tracks
- Design allows for easy cleaning around door tracks
- Sold in pairs - 1/8" (LT), 3/16" (SD), 1/4" (HD), and 3/8" (XHD)
- Standard size 48"
- Custom sizes available



POLY-BARREL COLUMN PROTECTOR

FEATURES:

- Tested to handle a 8,500 lb. forklift impact at 5 mph
- Deflect impact and guard against damage caused by forklifts, hand trucks, drum dollies, and personnel traffic
- Attach two halves with easy-to-install black straps; no tools required
- 6", 8", 10" or 12" round or square columns, 24" or 42" high
- Custom sizes available
- Optional red color for fire hydrants
- Other colors available upon request





STEEL COLUMN PROTECTOR helps protect I-Beams from forklifts and other equipment. The heavy-duty steel construction completely surrounds I-Beams and absorbs impact. Safety yellow finish is epoxy-based, heat-cured and has a powder coating that's designed to prolong life and durability.

FEATURES:

- Heavy-duty steel construction, high visibility safety yellow powder coating
- Complete with concrete and assembly hardware
- For 8"-10" I-Beams, 42" high, 150 lbs
- For 12"-14" I-Beams, 42" high, 205 lbs
- Custom sizes available



RACK POST PROTECTORS are barriers that help absorb and dissipate direct impact, making them a cost-effective solution to help in protecting your rack systems from lift truck impact.

FEATURES:

- Helps reduce potential injury from rack damage
- High visibility safety yellow powder coating
- Sizes: 12", 18", 24" and 36"
- Fits 4" columns, custom sizes available



DRAIN PIPE PROTECTORS are barriers that help absorb and dissipate direct impact, making them a cost-effective solution to help in protecting your pipe systems from impacts, anywhere inside or outside your facility.

FEATURES:

- Heavy-duty steel construction, high visibility safety yellow powder coating
- A smart investment to eliminate damage to unprotected drain pipes in the busy industrial area
- Two versatile models available: wall mount & I-Beam mount
- Engineered to help absorb and dissipate impact

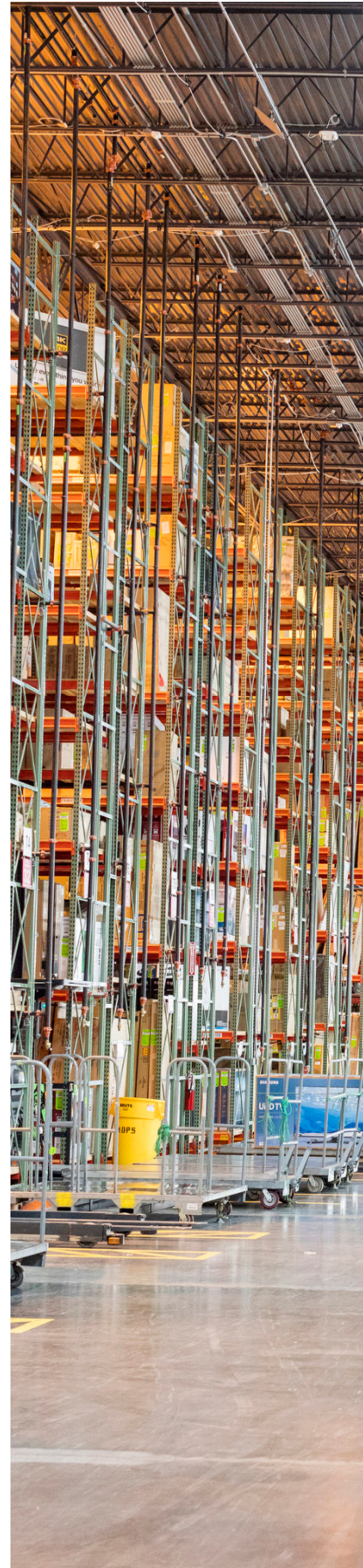



FORK SENTRY is a heavy-duty barrier to help protect machinery and personnel from lift truck traffic. Rugged construction barrier provides safety to company assets.

FEATURES:

- Heavy-duty, gusseted, 8" high construction
- High visibility safety to machinery, personnel and company assets
- Helps protect from lift truck and fork damage
- Often used in cold-storage facilities to protect insulated walls
- Various sizes available

END OF RACK PROTECTORS

FEATURES:

- Helps protect rack from damage
- Constructed of rugged steel plates
- High visibility safety yellow powder coating
- Available in various heights and lengths
- Single or double-sided kits available



WHEEL CHOCKS are blocks or wedges that get used to secure a wheel. Choosing the appropriate chock for the job is important as needs varies depending on the size of tires to be secured and the weight of the vehicle and the grade. OSHA recommends two wheel chocks per dock position in the absence of a vehicle restraint. Optional chain lengths, signange, and chock hangers available.



MOLDED/URETHANE WHEEL CHOCK

FEATURES:

- Available in molded and urethane
- Designed to fit both the tire or the pavement
- Available in black and orange



LAMINATED WHEEL CHOCK

FEATURES:

- Extra heavy-duty laminated rubber pads compressed between steel plates
- Contoured to fit tire; reversible

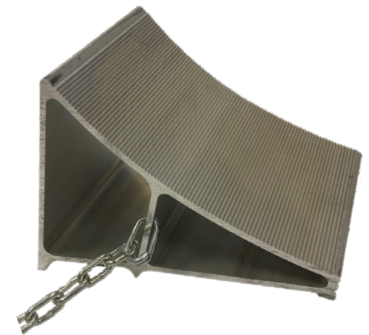

ALUMINUM WHEEL CHOCK

FEATURES:

- Light weight, non-sparking extruded aluminum
- Surface gripping teeth on underside



WHEEL GUIDES are a high-visibility safety yellow heavy-duty guide that helps direct the truck into the correct position at your dock.



WHEEL GUIDE

FEATURES:

- Guides truck to help prevent damage
- High visibility safety yellow
- Heavy-duty pipe style guides with dual mounting plates
- Standard size is 8' or 12' in length

WHEEL GUIDE WITH FLARE

FEATURES:

- Guides truck to help prevent damage
- High visibility safety yellow
- Heavy-duty 5-1/2" diameter pipe
- Available in 8', 9', or 10' sizes with 32" RH or LH flare

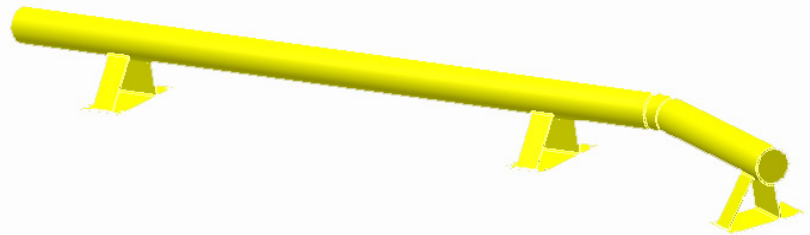

BUMPERS help protect your dock & building with steel faced, laminated, and molded bumpers from APS Resource.

DOCK DEFENDERS are steel faced, built for durability. It can withstand more than 75,000 lbs of pressure and carries a 10-year warranty with APS Resource. With the increased traffic of air-ride trailers and the usage of yard jockeys, the Dock Defender™ is the answer to the abusive loading dock environment.



MOLDED BUMPERS

- Molded in one piece of all new nylon and new polyester reinforced rubber
- Bumper to have a durometer reading of 80 plus or minus 5, tensile strength of 950-1050 PSI, and an impact recovery of 95%



LAMINATED BUMPERS

- Resilient rubber material of bumpers shall be rubberized-fabric truck tires cut to uniform size pads and punched to receive 3/4" supporting rod



STEEL FACE BUMPERS

- Resilient rubber material of bumpers cut to uniform size with overall projection of 5-1/4" or 6-3/4"; punched to receive 3/4" supporting rods
- Bumper to have 3/8" steel face plate equal to the rubber surface dimensions

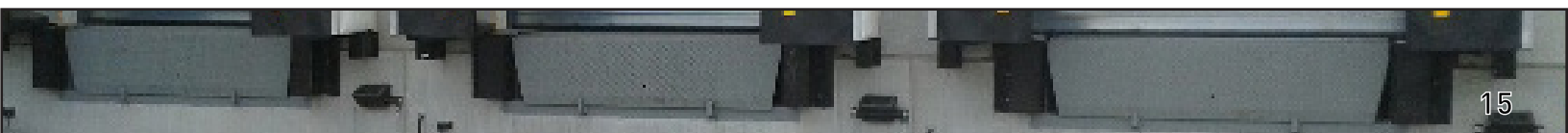



PIPE BOLLARDS

FEATURES:

- Protection for loading docks, door jambs and other in-plant areas susceptible to a moving vehicle collision
- Available in heavy-duty 6" or 4" bolt-down pipe
- Powder coated safety yellow for high visibility



BOLLARD COVERS

FEATURES:

- Enhance your property's appearance without costly painting or clean-up
- Fit securely over existing bollard posts
- Constructed of 1/8" thick, high density, UV stabilized polyethylene for durability and long life
- OSHA yellow; enhances visibility with red or blue reflective stripes
- Various sizes available



TRAILER STABILIZERS OSHA recommends trailer stabilizers to help reduce accidents from trailer-tip and landing gear collapse during loading and unloading, when a tractor does not support the trailer.

FEATURES:

- Static capacity: 100,000 lbs.
- Lifting capacity: 50,000 lbs.
- Two-speed gear box
- Service range: 41-3/4" to 55-1/4"
- Large 16" solid urethane tires



BELTED VISUAL BARRIER

FEATURES:

- 18 ft. yellow/black 3" stripe for high visibility
- Trak-Sentry with visual barrier 48" high door track protection (optional)



STEEL VISUAL BARRIER

FEATURES:

- 4 ft. tall
- Expandable to 18 ft.
- Lightweight design
- Additional double-wide (22') wheeled cart design available
- High visible strobe light for added safety (optional)



APS RESOURCE TRAINING CENTER

The APS Resource Training Center was designed specifically to educate distributors, technicians, end users, architects and contractors about proper warehouse design, safety and product selection. Based in Mequon, Wisconsin (a suburb of Milwaukee), the APS Resource Training Center provides a unique opportunity to operate and evaluate APS Resource products firsthand with unparalleled access to our manufacturing operation, one-on-one interaction with our engineering, tech, and sales teams, a full warehouse tour and a thorough demonstration of the products that best suit your application.



MOBILE SHOWROOM

Unable to travel to Mequon? Our Mobile Academy will come to you. Our custom 53-foot, completely enclosed and temperature-controlled trailer features full-sized, fully functional equipment demo units comprising a full portfolio of loading dock and warehouse solutions. The Mobile Showroom provides a portable, interactive classroom to learn more about effective loading dock design and proper equipment application. Best of all, we deliver it right to your doorstep, making it one of the most comprehensive and convenient educational resources available in the industry.



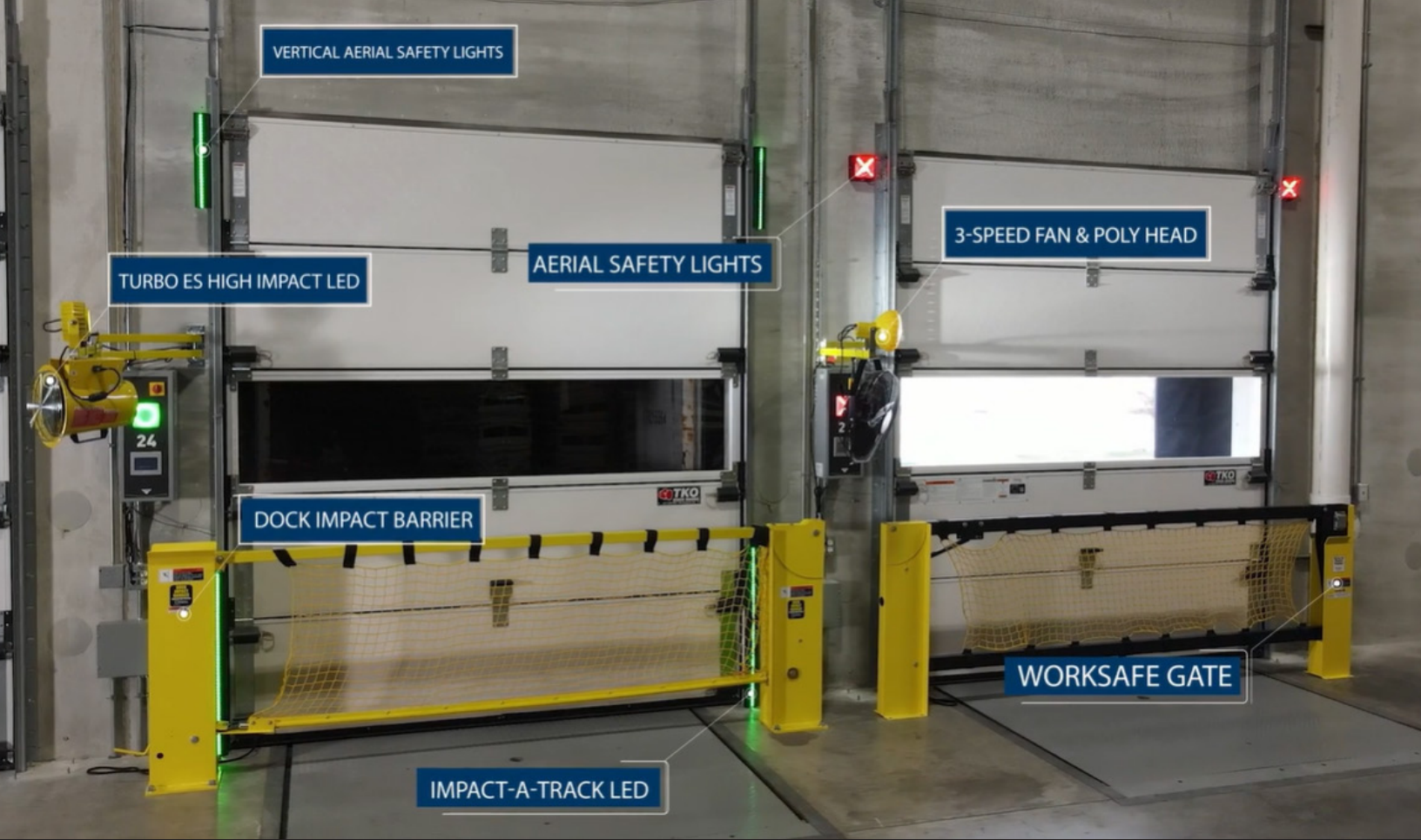

YOUR LOCAL AUTHORIZED APS DISTRIBUTOR:



PLACE STICKER HERE



APS Resource[®]
Your Aftermarket Solution

6219 WEST EASTWOOD CT
MEQUON, WI 53092

USA: 262-518-1000

INFO@APSRESOURCE.COM



(Scan or click here for product videos)