

# Heavy Duty Pit Extender Kit

## SPECIFICATION

The APS Resource Heavy Duty Pit Extender Kits are the safe and reliable answer to correcting pit dimensions. The front bracket provides an extension across the entire pit width, and the rear pit filler comes standard with durable tubular legs. Both ensure consistent capacity and safe support of the dock leveler.

### Design Highlights

- Kit includes both rear pit filler and front cantilever bracket (components also sold separately)
- Rear pit filler legs can be shimmed to fit pit depth
- Front bracket mounts to dock face, pit floor and existing curb steel. Anchors are included
- Available in projections of 2" - 8" in increments of 1"
- Available in pit widths to accommodate 6', 6 ½' and 7' levelers
- APS Resource warrants these products will be free from defects in material and workmanship under normal use for (1) year

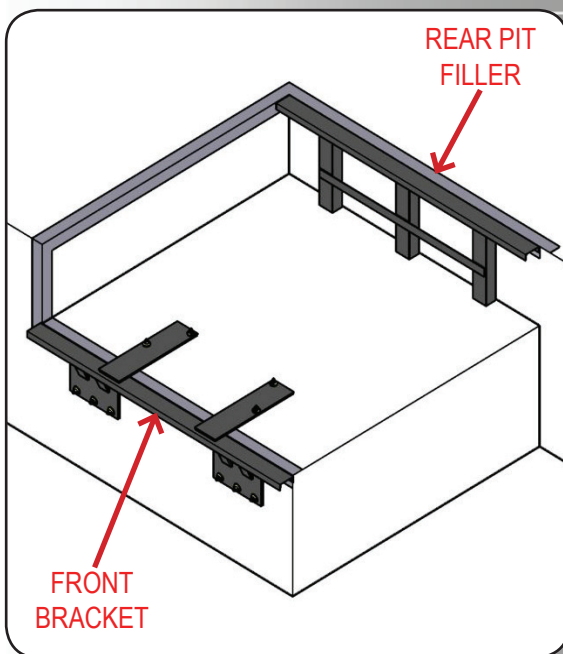

### Project Information

Job Name \_\_\_\_\_

Address \_\_\_\_\_

General Contractor \_\_\_\_\_

Distributor \_\_\_\_\_

Model \_\_\_\_\_

Quantity \_\_\_\_\_

### Certified For Construction

By \_\_\_\_\_

Company \_\_\_\_\_

Address \_\_\_\_\_

Date \_\_\_\_\_

